



SAS Micropile Manual

Basic dimensioning and design recommendations

Table of Content:

	Page
System Description	2
Load Capacities	2
Minimum Drill Hole Diameter	3
Load Transfer to Ground	4
Corrosion Protection	5
Assembly Drawings	8
References	15
SAS Bar Table	16



System Description

Micropiles are small diameter piles; transferring compression, tension, and alternating loads mainly through skin friction to the surrounding ground. This concept of micropiles was developed in the 1950's. The use of continuous threaded bars as single, double, and triple bar micropiles was introduced in the 1970's.

The SAH micropiles comprises of a thread-bar as the principal load carrying element inside a pressure-grouted cement body. This continuous coarse SAH thread-bar allows the micropile to be installed in single sections, or in multiple sections, coupled together to any desired length.

Various corrosion protection systems are available to cope with environmental impact and performance life expectations.

Load Capacities of Pile

In accordance with EN1537 and PTI Recommendations for Ground Anchors, the following listed working load capacities for micropiles are based on a factor of 0.60 x Ptk (0.60 x UTS), that is 60 % of the nominal ultimate tensile strength.

Working Load Capacities for S 670/800 (grade 97) bar:

Bar Diameter		Bar Characteristics		Working Load
[mm]	[US #]	Yield Load	Ultimate Load	0.6 X UTS
		[KN]	[KN]	[KN]
25	8	329	393	236
28	9	413	493	296
30	10	474	565	39
35	11	645	770	462
43	14	973	1162	697
57.5	18	1740	2077	1246
63.5	20	2122	2534	1520
75	24	2960	3535	2121



Working Load Capacities for B 500/550 (grade 75 and grade 80) bar:

Bar Diameter		Bar Characteristics		Working Load
[mm]	[US #]	Yield Load	Ultimate Load	0.6 X UTS
		[KN]	[KN]	[KN]
25	8	329	393	236
28	9	413	493	296
32	10	474	565	39
40	11	645	770	462
50	14	973	1162	697
63.5 ¹⁾	20	2122	2534	1520

¹⁾ Diameter 63.5 mm bar is of grade 555/700 N/mm² (grade 80).

Minimum Drill Hole Diameter

Required drill hole diameter for single corrosion protected (SCP) and double corrosion protected (DCP) micropile depends on the ground conditions and drilling equipment setup, e.g. fully cased drill hole. The following are minimum internal hole diameters at which the piles do fit and do meet required cement grout coverage according EN 1537 for DCP micro piles.

Minimum drill hole diameter for single bar micropile:

Bar Diameter		SCP Micropile		DCP Micropile	
[mm]	[US #]	Without Coupler	With Coupler	Without Coupler	With Coupler
		Ø [mm]	Ø [mm]	Ø [mm]	Ø [mm]
25	8	60	80	90	100
28	9	65	85	90	100
30 & 32	10	70	90	95	105
35	11	75	100	95	105
40	11	75	100	120	130
43	14	80	115	120	130
50	14	85	115	140	150
57.5	18	95	140	140	150
63.5	20	100	150	140	150
75	24	115	145	140	150



Load Transfer to Ground

Micropiles transfer load mainly through skin friction into the surrounding ground. For pressure-grouted micropiles the minimum load transfer length can be presumed to equal an anchors bond length along the drill hole surface:

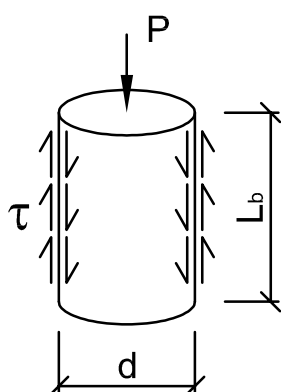

$$L_b = P / (\pi \times \tau \times d \times \gamma_p)$$

L_b = load transfer length

P = design load of micro pile

d = drill hole diameter

τ = bond stress at soil to cement grout interface

γ_p = safety factor

Empirical bond stress values at soil to cement grout interface for pressure grouted micro piles according to DIN 1054, Subsoil - Verification for earthworks and foundations:

Soil / Rock Type	Empirical Bond Stress Value [τ]	
	N/mm ² [MPa]	PSI
Cohesive Soil	0.10	15
Sand	0.15	20
Gravel	0.20	30
Weathered Marl, Chalk, Soft Shales	0.15 - 0.80	30 - 120
Soft Limestone, Slates, Hard Shales, Sandstone	0.80 - 1.70	120 - 250
Dolomite Limestone	1.40 - 2.10	200 - 300
Granite, Basalt	1.70 - 3.10	250 - 450

SAS thread-bar has a relative rib area of 0.075 to 0.080, which exceeds that of standard thread-bars. For cement grout strength in excess of 40 N/mm² a bond stress of $\tau_w = 5$ N/mm² for the serviceability limit state can be assumed between SAS thread-bar and surrounding cement grout.



According to PTI Recommendations for permanent ground anchors a safety factor of 2.0 should be applied to the bond stress value at the grout/ground interface. DIN 1054 is differentiating the safety factor to load conditions and source of bond stress value used.

Safety factors on bond stress values for micropiles according to DIN 1054 Subsoil - Verification for Earthworks and Foundations:

Load condition – Source of bond stress value	Safety Factor on Bond Stress [γ_p]
Compression loaded micropile At site investigated/tested bond stress value	1.20
Tension loaded micropile At site investigated/tested bond stress value	1.30
Compression and/or tension loaded micropile Using empirical bond stress values	1.40

Local standards and particular project-related safety factors on load capacities as well as allowable bond stress of soils have to be observed.

Corrosion Protection Systems

The pace of corrosion of steel members in the ground is largely depending on the aggressiveness of the surrounding environment. For the SAS Micropile system the following protection against corrosion can be applied:

- sacrificial steel
- bare bar in cement grout (SCP) single corrosion protection
- hot dip galvanized bar in cement grout
- epoxy coated bar in cement grout
- bare bar in pre-grouted PE sheathing (DCP) double corrosion protection

Micropiles with a performance-life expectation of less than 2 years are temporary piles. A performance life-span of 2 to 7 years can be considered for semi permanent. Micropiles with a performance-life of more than 7 years are permanent piles.



Corrosion of bare steel in the ground:

Steel elements can be oversized to allow for loss of cross sectional area due to corrosion. Depending on the ground conditions, the European standard for micropiles, EN 14199, is suggesting the following loss of thickness of bare steel in the ground:

Soil condition	Yearly loss of steel thickness due to corrosion [mm]
Undisturbed natural soils (sand, silt, clay, schist,...)	0.012
Polluted natural soils and industrial grounds	0.030
Aggressive natural soils (swamp, march, peat,...)	0.033
Non-compacted and non-aggressive fills (clay, schist, sand, silt,...)	0.022
Non-compacted and aggressive fills (ashes, slag,...)	0.058

The values above are for guidance only. Local conditions should be considered and suitable values taken into account.

SCP - Single Corrosion Protection:

Bare thread-bars, inside a column of cement-grout are considered having single corrosion protection. This single corrosion protection is adequate for temporary piles as well as permanent piles loaded with compression only. EN 1537 for Ground Anchors as well as the American PTI Anchor Recommendations is considering a service life of less than 24 month as temporary.

Hot Dip Galvanizing:

Micropiles in less aggressive environment can be protected semi-permanent by hot dip galvanizing of the thread-bars in accordance to EN 1461, BS 729, or ASTM A 153.

Epoxy coating:

Micropiles in less aggressive environment can be protected semi-permanent by epoxy coating of the thread-bars in accordance to BS 7295, ASTM A 934, or A 775.



DCP - Double Corrosion Protection:

Permanent piles, tensile loaded piles, or piles in aggressive media (such as seawater), should have double corrosion protection applied. This is provided by centralizing the thread-bar in a corrugated plastic sleeve and by filling the annulus between the bar and the sleeve with a non-shrink cement grout, preferably in a qualified workshop.

Corrosion Protection Matrix:

For the following suitability matrix on corrosion protection systems a soil corrosiveness according to DIN EN 12501 was considered. Further the performance life was classified to temporary (less than 2 years), semi permanent (two to 7 years), and permanent (more than 7 years).

Recommended corrosion protection systems in light of performance life and soil corrosiveness:

Performance Life [years]	Corrosion Protection System	Soil Corrosiveness ¹⁾		
		low	medium	high
less than 2 years	sacrificial steel	√	√	√
	bare bar in cement grout (SCP)	√	√	√
	hot dip galvanized bar in cement grout			√
	epoxy coated bar in cement grout			√
	pre-grouted HDPE sheathed bar in cement grout (DCP)			√
2 to 7 years	sacrificial steel	√	√	√
	bare bar in cement grout (SCP)	√	√	√ ²⁾
	hot dip galvanized bar in cement grout	√	√	√
	epoxy coated bar in cement grout	√	√	√
	pre-grouted HDPE sheathed bar in cement grout (DCP)		√	√
more than 7 years	sacrificial steel	√	√	√
	bare bar in cement grout (SCP)	√ ²⁾	√ ²⁾	
	hot dip galvanized bar in cement grout	√		
	epoxy coated bar in cement grout	√		
	pre-grouted HDPE sheathed bar in cement grout (DCP)	√	√	√

1) In accordance with DIN EN 12501.

2) Suitable for micropiles loaded by compression only.



SAS Micropile Assembly Drawings

As mentioned at the very beginning, micropiles transfer compression, tension, or alternating loads to the surrounding ground. At the pile head and coupler units the path of force is different for tension vs. compression loaded micropiles. Following sketches show micropile coupler units, matching the path of load transfer:

Compression Load

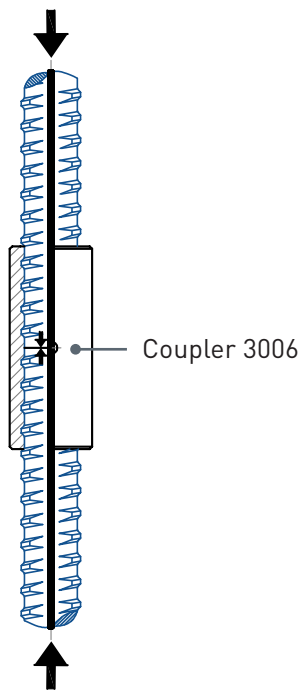

Tension Load

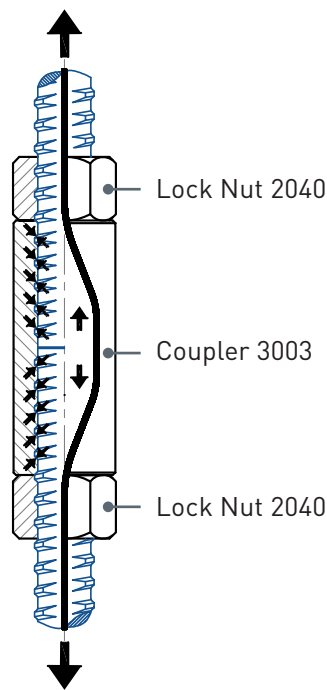

Alternating Load

[compression load cycle]

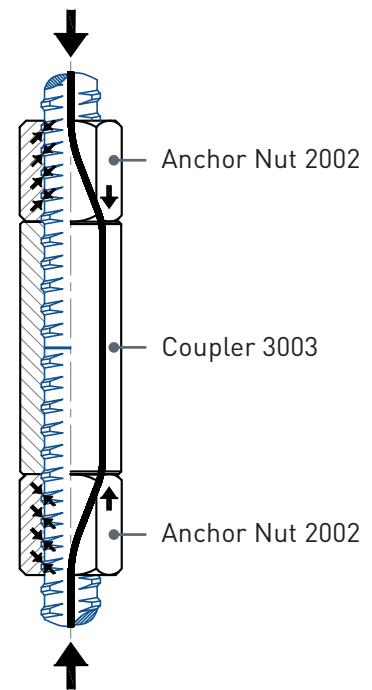

The following micropile assembly drawings reflect this fact by altering the anchor and coupler units for single corrosion protected (**SCP**) and double corrosion protected (**DCP**) systems:

SCP Pile for Tension and Compression Load	Page	9
SCP Pile for Compression Load	Page	10
SCP Pile for Tension Load	Page	11
DCP Pile for Tension and Compression Load	Page	12
DCP Pile for Compression Load	Page	13
DCP Pile for Tension Load	Page	14



SCP¹⁾ Tension and Compression Pile

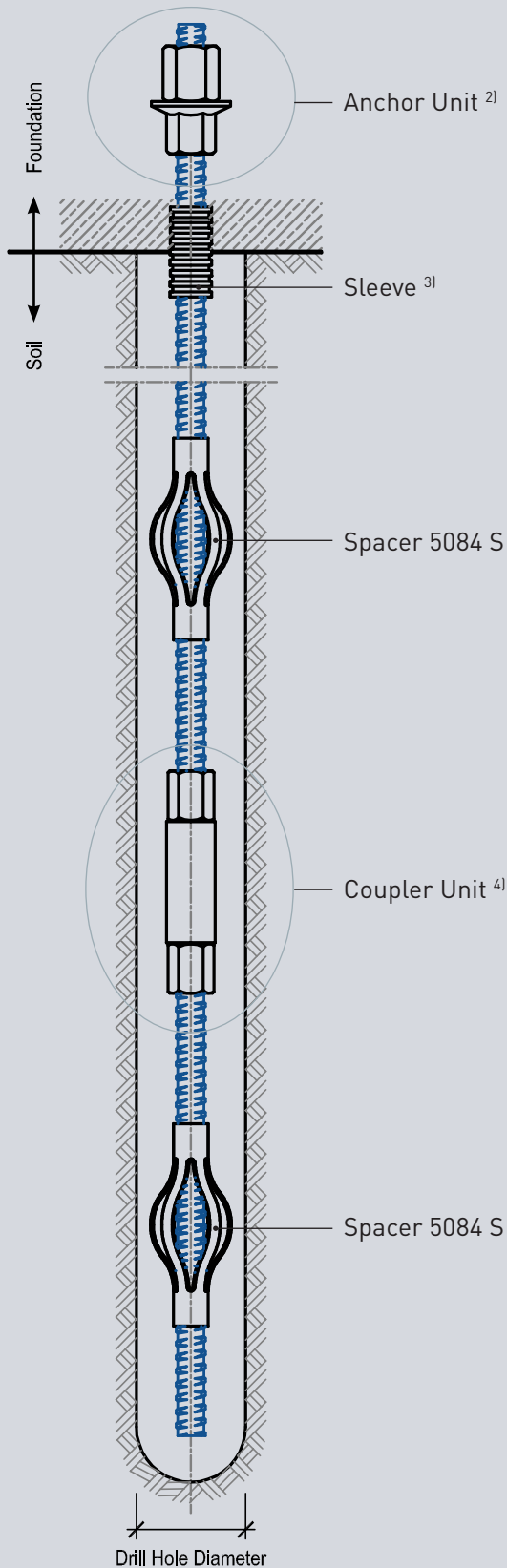

Description	Unit	QTY / Total QTY
No of Piles	pc	
Steel Grade	N/mm ²	
Thread-bar dia	mm	
Thread-bar length	m	/
Anchor Unit ²⁾		
with anchor plate	pc	/
with anchor piece	pc	/
Sleeve ³⁾	pc	/
Spacer	pc	/
Coupler Unit ⁴⁾	pc	/

Notes and Details

1) **SCP**: Single Corrosion Protection

2) The **anchor unit** consists of 1 no of anchor nut 2002 and 1 no of anchor piece 2073.

The anchor piece 2073 may be replaced by an anchor nut 2002 and an anchor plate as shown below:

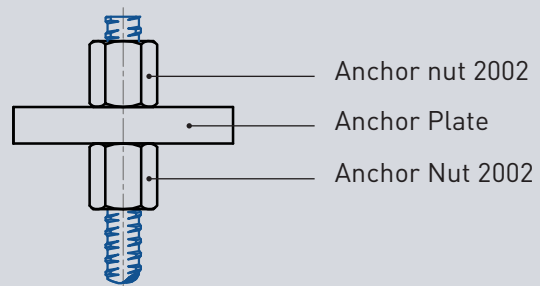

3) The **sleeve** is approximately 80 cm in length, including an internal centralizing PE cord.

4) The **coupler unit** does consists of a coupler 3003 and 2 no. of long lock nuts 2003.



SCP¹⁾ Compression Pile

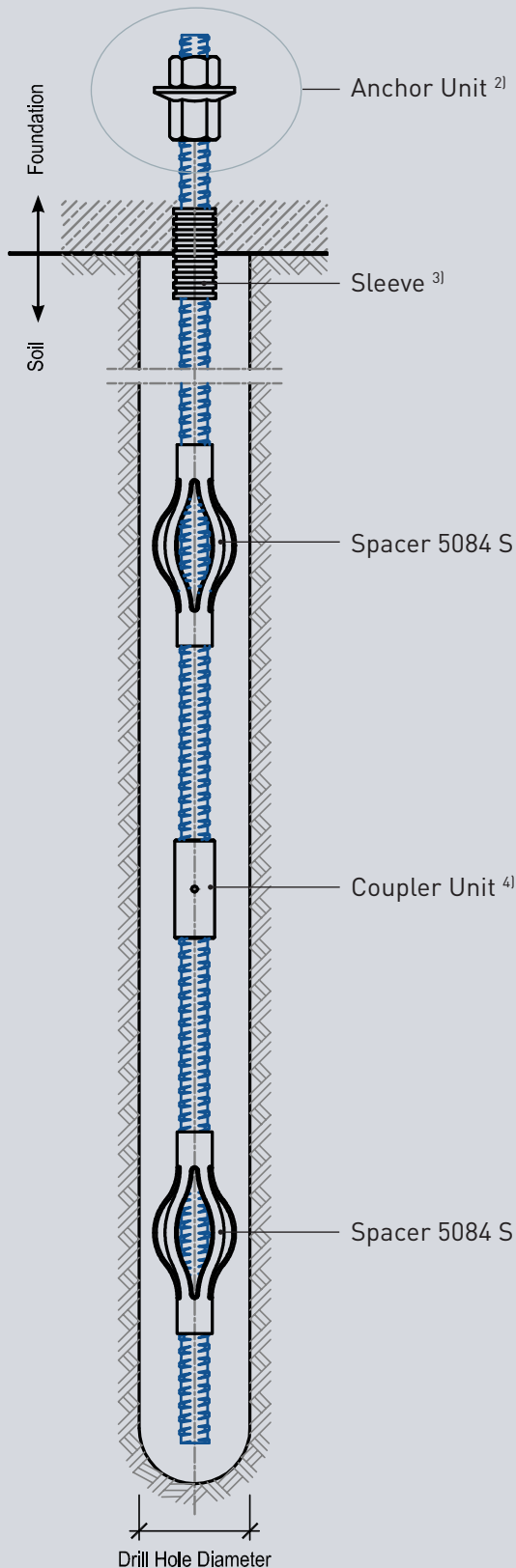

Description	Unit	QTY / Total QTY
-------------	------	-----------------

No of Piles	pc	
Steel Grade	N/mm ²	
Thread-bar dia	mm	
Thread-bar length	m	/
Anchor Unit ²⁾		
with anchor plate	pc	/
with anchor piece	pc	/
Sleeve ³⁾	pc	/
Spacer	pc	/
Coupler Unit ⁴⁾	pc	/

Notes and Details

1) **SCP**: Single Corrosion Protection

2) The **anchor unit** consists of 1 lock nut 2040 and 1 anchor piece 2073.

The anchor piece 2073 may be replaced by an anchor nut 2002 and an anchor plate as shown below:

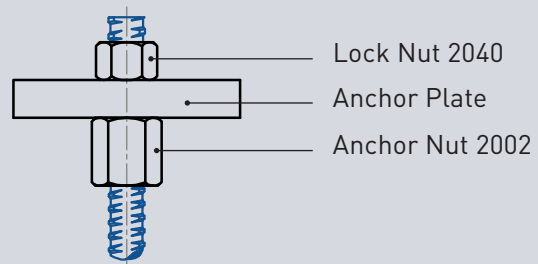

3) The **sleeve** is approximately 80 cm in length, including an internal centralizing PE cord.

4) The **coupler unit** consists of 1 compression coupler 3006.



SCP¹⁾ Tension Pile

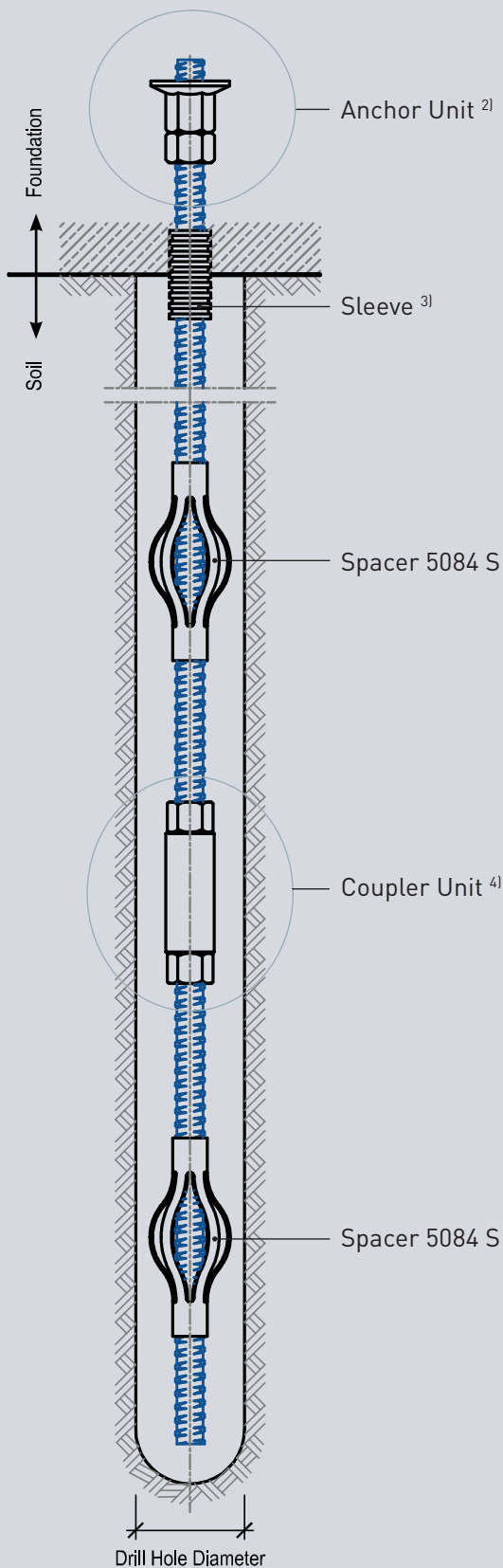

Description	Unit	QTY / Total QTY
No of Piles	pc	
Steel Grade	N/mm ²	
Thread-bar dia	mm	
Thread-bar length	m	/
Anchor Unit ²⁾		
with anchor plate	pc	/
with anchor piece	pc	/
Sleeve ³⁾	pc	/
Spacer	pc	/
Coupler Unit ⁴⁾	pc	/

Notes and Details

1) **SCP**: Single Corrosion Protection

2) The **anchor unit** consists of 1 anchor piece 2073 and 1 lock nut 2040.

The anchor piece 2073 may be replaced by an anchor nut 2002 and an anchor plate as shown below:

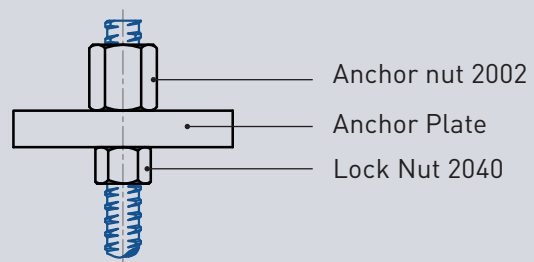

3) The **sleeve** is approximately 80 cm in length, including an internal centralizing PE cord.

4) The **coupler unit** consists of a coupler 3003 and 2 lock nuts 2040.



DCP¹⁾ Tension and Compression Pile

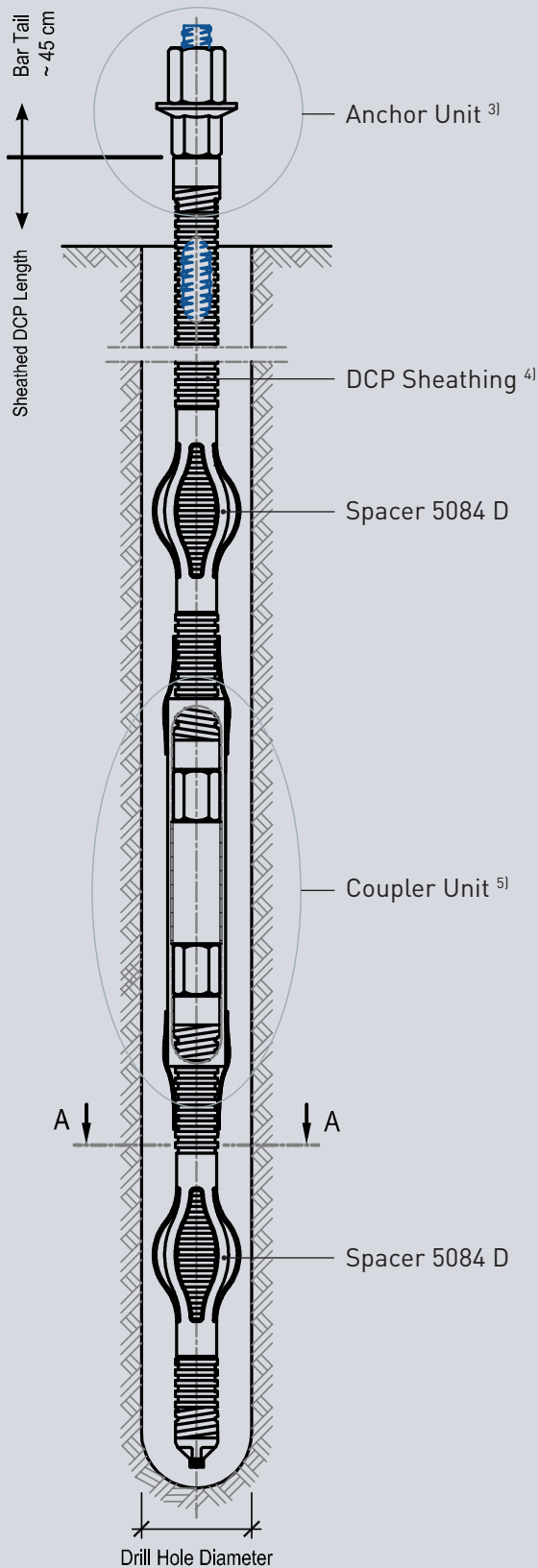

Description	Unit	QTY / Total QTY
No of Piles	pc	
Steel Grade	N/mm ²	
Thread-bar dia	mm	
Pile length ²⁾	m	/
Anchor Unit ³⁾		
with anchor plate	pc	/
with anchor piece	pc	/
Spacer	pc	/
Coupler Unit ⁵⁾	pc	/

Notes and Details

- 1) **DCP:** Double Corrosion Protection
- 2) The **pile length** consists of the DCP-sheathed ⁴⁾ length plus approximately 45 cm (1.5 foot) protruding bk bar tail for the anchor unit.
- 3) The **anchor unit** consists of an anchor piece 2073 and 1 no of anchor nut 2002. The anchor piece 2073 may be replaced by an anchor nut 2002 and an anchor plate.
- 4) The **DCP sheathing** consists of pre-assembled and pre-grouted corrugated sheathing, including for internal centralizers, grout-, and vent cap.
- 5) The **coupler unit** consist of a coupler, two anchor nuts, anti corrosion compound-filled coupler housing, and two heat shrink sleeves for sealing of the coupler housing to the corrugated sheathing.

Section A - A:

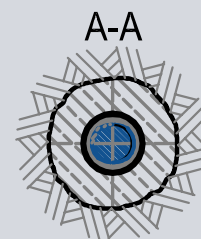



DCP¹⁾ Compression Pile

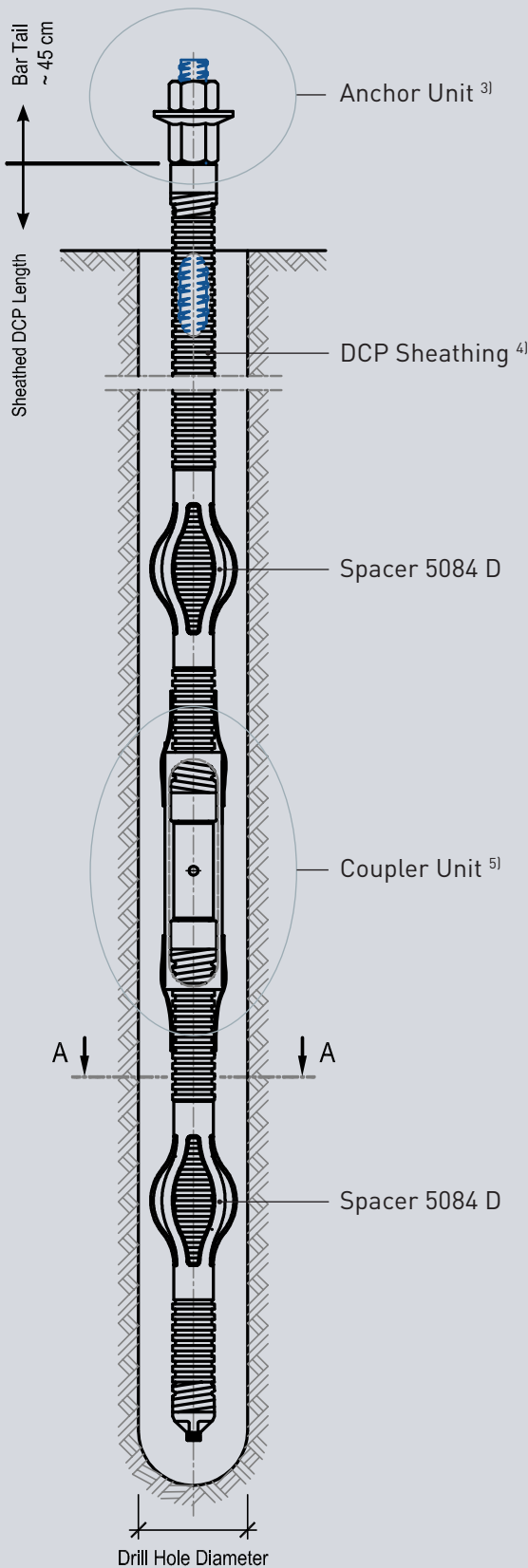

Description	Unit	QTY / Total QTY
-------------	------	-----------------

No of Piles	pc	
Steel Grade	N/mm ²	
Thread-bar dia	mm	
Pile length ²⁾	m	/
Anchor Unit ³⁾		
with anchor plate	pc	/
with anchor piece	pc	/
Spacer	pc	/
Coupler Unit ⁵⁾	pc	/

Notes and Details

- 1) **DCP:** Double Corrosion Protection
- 2) The **pile length** consists of the DCP-sheathed ⁴⁾ length plus approximately 45 cm (1.5 foot) protruding black bar tail for the anchor assembly.
- 3) The **anchor unit** consist of 1 anchor piece 2073 and one lock nut 2040.
The anchor piece 2073 may be replaced by an anchor nut 2002 and an anchor plate.
- 4) The **DCP sheathing** consists of pre-assembled and pre-grouted corrugated sheathing, including for internal centralizers, grout-, and vent cap.
- 5) The **coupler unit** consist of a compression coupler, anti corrosion compound-filled coupler housing, and two heat shrink sleeves for sealing of the coupler housing to the corrugated sheathing.

Section A - A:

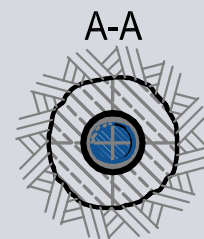



DCP¹⁾ Tension Pile

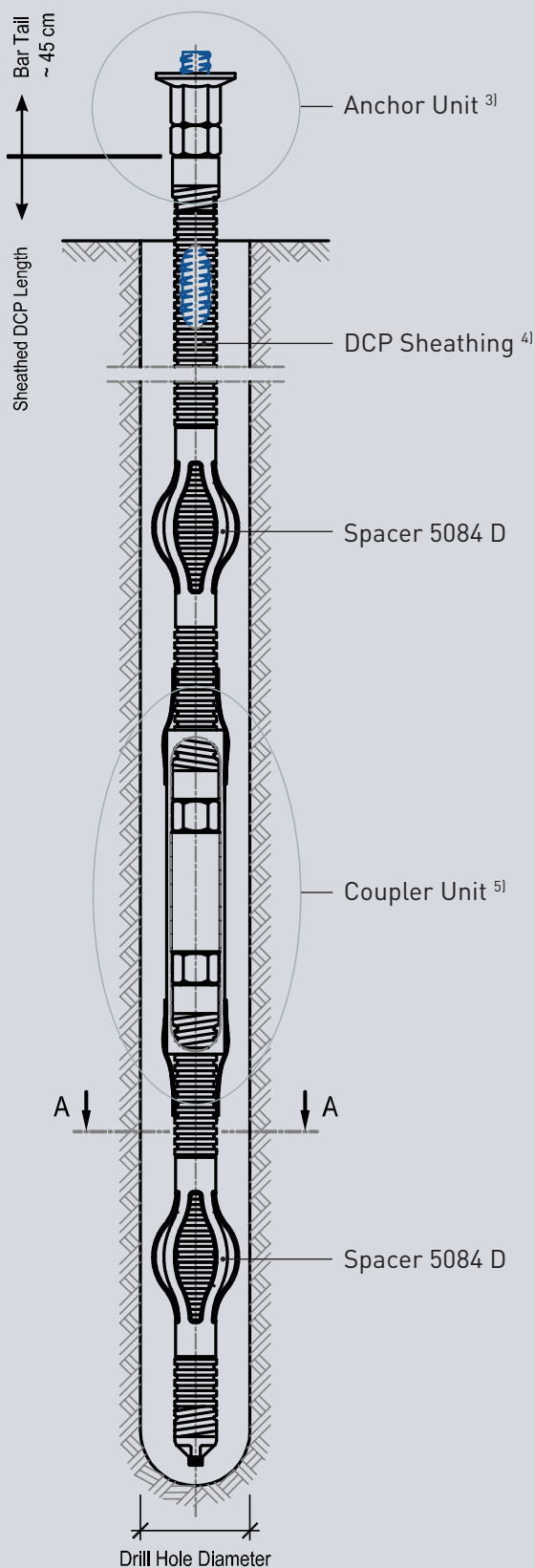

Description	Unit	QTY / Total QTY
-------------	------	-----------------

No of Piles	pc	
Steel Grade	N/mm ²	
Thread-bar dia	mm	
Pile length ²⁾	m	/
Anchor Unit ³⁾		
with anchor plate	pc	/
with anchor piece	pc	/
Spacer	pc	/
Coupler Unit ⁵⁾	pc	/

Notes and Details

- DCP:** Double Corrosion Protection
- The **pile length** consists of the DCP-sheathed⁴⁾ length plus approximately 45 cm (1.5 foot) protruding black bar tail for the anchor unit.
- The **anchor unit** consist of 1 anchor piece 2073 and 1 lock nut 2040.
The anchor piece 2073 may be replaced by an anchor nut 2002 and an anchor plate.
- The **DCP sheathing** consist of pre-assembled and pre-grouted corrugated sheathing, including for internal centralizers, grout-, and vent cap.
- The **coupler unit** consist of the coupler, two lock nuts, anti corrosion compound-filled coupler housing, and two heat shrink sleeves for sealing of the coupler housing to the corrugated sheathing.

Section A - A:

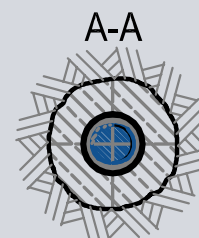



Approvals

Z-1.1-1	SAS 555 Thread-Bar (S555/700) as load bearing element for micro-piles and soil nails
ETA request No. 01.03/10	Application for European Technical Approval “Kit For Micropiles” in progress at EOTA TB

Standards

EN 445	Grout for prestressing tendons – Test methods
EN 447	Grout for prestressing tendons – Specification for common grout
EN 1537	Execution of special geotechnical works – Ground anchors
EN 12501-1 & 2	Protection of metallic materials against corrosion. Corrosion likelihood in soil.
Pr EN 14199	Execution of special geotechnical works – Micropiles
EN ISO 15630-1	Steel for the reinforcement and prestressing of concrete – Test methods
ETAG 013	Post Tensioning Kits for prestressing of Structures
ISO/CD 15835-1	Steel for reinforcement of concrete – Mechanical splices for bars – Part 1: Requirements
ISO/CD 15835-2	Steel for reinforcement of concrete – Mechanical splices for bars – Part 2: Test methods

Publications

Recommendations for Prestressed Rock and Soil Anchors – Post-tensioning Institute, 2004

For more detailed information and queries please directly contact the R&D department at Stahlwerk Annahütte.



SAS Bar Table

Yield Stress / Ultimate Stress	Nom. - \emptyset	Yield Load	Ultimate Load	Cross Area	Weight	Elongation	
						A _{gt} [%]	A ₁₀ [%]
[N/mm ²]	[mm]	[kN]	[kN]	[mm ²]	[m/to]	[kg/m]	
SAS 500 (BSt 500 S) / grade 75							
B 500 / 550	12	57	62	113	1123.6	0.89	6 10
	14	77	85	154	826.4	1.21	
	16	100	110	201	632.9	1.58	
	20	160	175	314	404.9	2.47	
	25	245	270	491	259.7	3.85	
	28	310	340	616	207.0	4.83	
	32	405	440	804	158.5	6.31	
	40	630	690	1260	101.3	9.87	
	50	980	1080	1960	64.9	15.40	
S 555/700 / grade 80	63.5	1760	2215	3167	40.2	24.86	5 10
SAS 670 / grade 97							
S 670 / 800	18	170	204	254	500.0	2.00	5 10
	22	255	304	380	335.6	2.98	
	25	329	393	491	259.7	3.85	
	28	413	493	616	207.0	4.83	
	30	474	565	707	180.2	5.55	
	35	645	770	962	132.5	7.55	
	43	973	1162	1452	87.7	11.40	
	57.5	1740	2077	2597	49.1	20.38	
	63.5	2120	2534	3167	40.2	24.86	
	75	2960	3535	4418	28.8	34.68	
SAS 950 / 1050 / grade 150							
St 950 / 1050	18	230	255	241	510.2	1.96	5 7
	26.5	525	580	551	223.2	4.48	
	32	760	845	804	153.1	6.53	
	36	960	1070	1020	120.9	8.27	
	40	1190	1320	1257	97.9	10.21	
	47	1650	1820	1735	70.9	14.10	
St 835 / 1035	57	2155	2671	2581	47.7	20.95	4 7
	65	2780	3447	3331	36.9	27.10	
	75	3690	4572	4418	27.9	35.90	
SAS V2 580 (1.4301)							
580 / 650 <i>stainless</i>	23	249	280	430	295.0	3.40	30 [A ₅]
	26	313	351	540	234.2	4.35	
SAS V4 580 (1.4404)							
580 / 650 <i>stainless</i>	23	249	280	430	295.0	3.40	30 [A ₅]
	26	313	351	540	234.2	4.27	
SAS 900 / 1100 - Type FA / grade 160							
St 900 / 1100 - Type FA <i>weldable</i>	15	159	195	177	694.4	1.44	3 7
	20	283	345	314	390.6	2.56	
	26.5	461	568	551	223.2	4.48	
<i>not weldable</i> - Type E	26.5	461	568	551	223.2	4.48	4 7
SAS 850 - cold rolled / grade 120							
St 850 - Type FS <i>cold rolled, weldable</i>	15	140	170	191	666.7	1.50	10 [A ₅]
	20	245	280	331	384.6	2.60	
	26.5	385	490	586	217.4	4.60	

DIBt approval

ETA approval

DIBt approval

Stahlwerk Annahütte Max Aicher GmbH & Co. KG, D-83404 Hammerau / Germany
 Tel. +49 (0)86 54 / 4 87-0 • Fax +49 (0)86 54 / 4 87-964
 stahlwerk@annahuette.com • www.annahuette.com



This manual is subject to changes.

70109 RU